

NUFLO Liquid Turbine Flow Meters

Accurate Flow Measurement

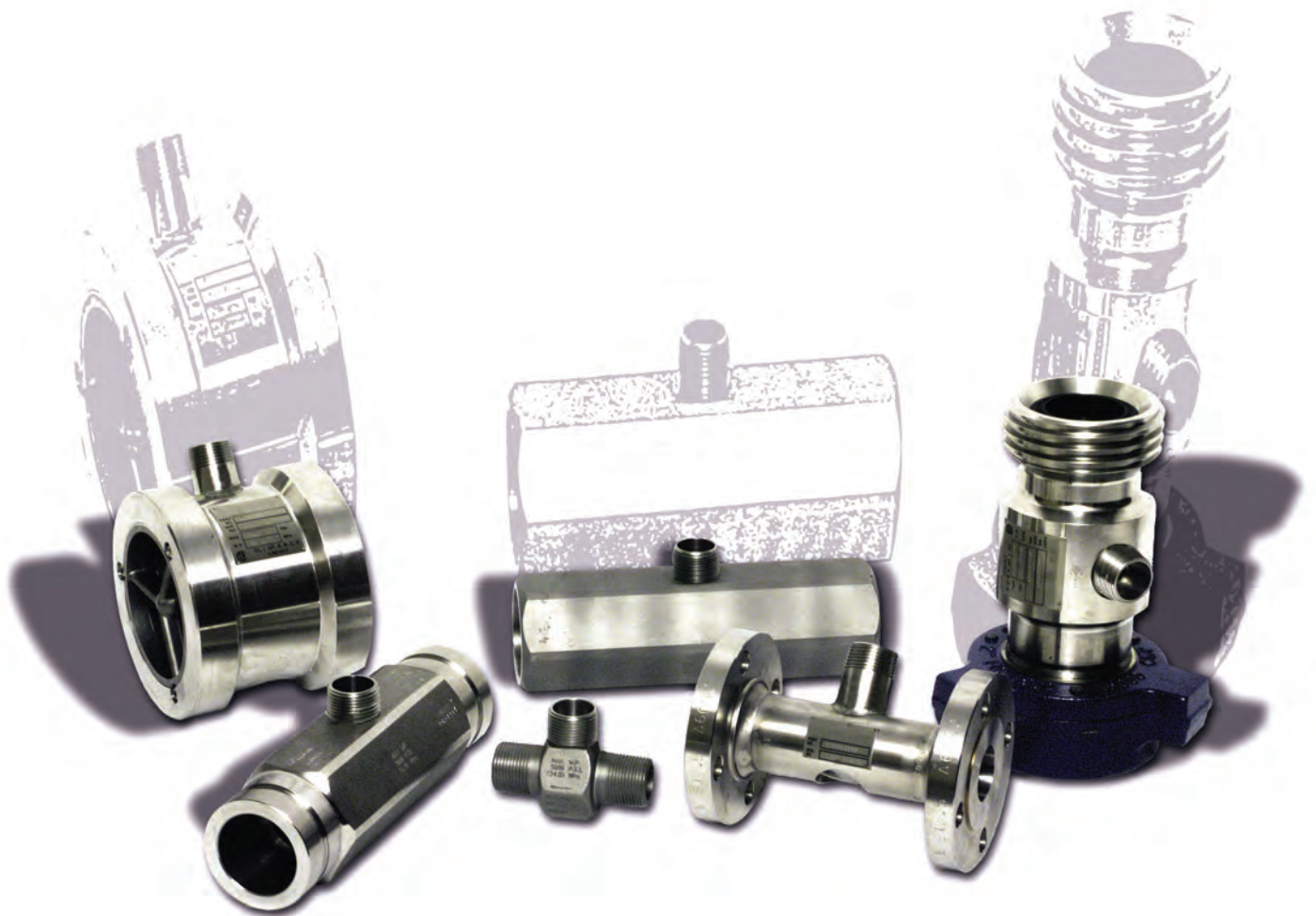

In 1957, this flow meter was developed with a tungsten-carbide shaft and bearing to withstand the rugged conditions of the oil field. Over the years, it has earned an unsurpassed reputation for withstanding severe punishment while maintaining operational and measurement integrity. Today, it remains a strong seller among Cameron's NUFLO™ liquid measurement products.

NUFLO turbine flow meters indicate flow rate and measure total throughput of a liquid line. As liquid flows through the meter and over the rotor, the rotor turns at a speed that is directly proportional to the flow rate. A magnetic pickup senses the rotor blades as they pass and generates an electrical (sine wave) signal. These electrical pulses are then transmitted to the flow measurement readout equipment.

Benefits

Accurate and repeatable measurement

An economical solution for turbine flow meter applications

Easy installation and a variety of end connections

Minimum maintenance required

Long service life even in severe applications

First Class Design Delivers First Class Performance

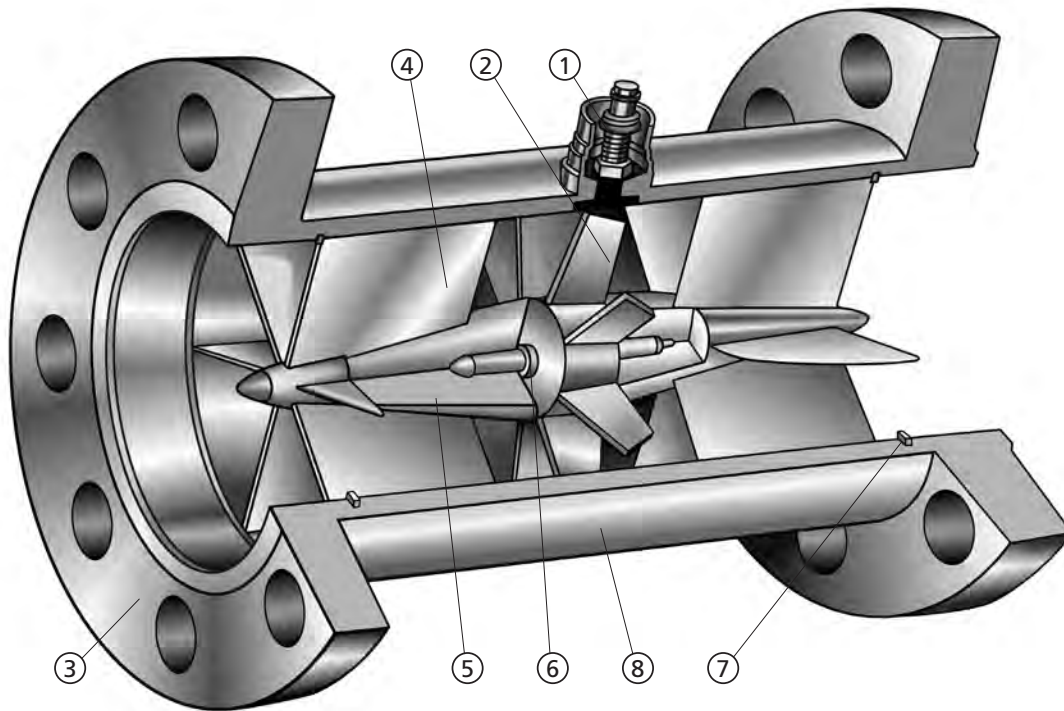

1. Permanent 1" MNPT conduit connection is standard.
2. Rotor is pitched and pre-calibrated to determine accuracy.
3. End Connections available as a flanged, threaded, grooved, EZ-IN™ and WECCO® 1502.
4. Flow Vanes increase performance at low rates.
5. Flow Vane Hub supports rotor assembly.
6. Rotor Shaft, Bearings and Thrust Ball are made of tungsten carbide for long service without lubrication other than by the process liquid.
7. Retaining Rings make disassembly easy.
8. Flow Meter Body is a sturdy, one-piece construction, precision finished.

Applications

Cameron offers turbine flow meters in a variety of end connections and accuracy levels. Typical applications are:

- Water-injection measurement
- Heater treaters
- Test and production separators
- Disposal wells
- CO₂ injection
- Steam generator fuel and feed water
- Metering liquid fertilizer
- Water, fuel and chemical measurement in plant settings
- Chemical tank loading and unloading
- Measuring liquid propane
- *In-situ* mining and leaching

Accuracy

Cameron offers two meter grades to satisfy various linearity requirements. The standard grade meter is a cost-effective solution for applications requiring accuracy of 1% or less. For higher accuracy, an industrial grade meter can be used. Greater accuracy may be achieved if the expected flow range is specified.

Meter Grade	Linearity	Repeatability
Standard ¹	± 1% of reading	± 0.05%
Industrial ¹	± 0.5% of reading	± 0.02%
Enhanced accuracy	Consult factory	Consult factory

¹ For 3/8" meters, linearity is ± 2% of reading (standard) and ± 1% of reading (industrial).

Temperature Range (magnetic pickup)

	Temperature Range	Flow Meter Size
Standard	-67° F to 250° F (-55° C to 107° C)	3/8" through 3/4"
	-67° F to 250° F (-55° C to 121° C)	7/8" through 8"
Medium	-67° F to 450° F (-55° C to 232° C)	all sizes

Note: Consult Cameron's Measurement Systems division for any use of turbine flow meters below -20° F (-29° C) or above 250° F (121° C).

Compliances

- CSA certified for hazardous areas, Class I, Div. 1, Groups A, B, C, D
- Meters with maximum working pressures below 7500 psi are compliant with ANSI 12.27.01-2003 single seal
- EZ-IN meters and WECO 1502 union meters available with CE mark for Pressure Equipment Directive (PED, 97/23/EC)

Materials of Construction

- Meter body (standard): Grade 316L stainless steel¹
- Meter body (high pressure): A286 stainless steel¹
- Vanes: Grade 316L stainless steel
- Rotor: CD-4MCu
- Shaft and bearings: Tungsten carbide

¹Traceability of pressure-containing components available on request.

Optional Materials

Shaft

Binderless carbide for enhanced corrosion resistance to selected chemicals.

Shaft and Bearings

Silver brazing to withstand temperatures to 550° F (288° C) and chemicals that attack epoxy bonding bearing materials.

Rotor

Nickel plating for enhanced corrosion resistance to selected chemicals (especially acids that corrode ferrous materials).

Meter Size Selection

Flow meter size selection should be based on the instantaneous flow rate of the line into which the meter will be mounted and on the meter pressure drop. Meter size should never be based on the nominal piping size of the installation. Refer to the linear flow range chart (page 3) and the pressure drop curve chart (page 6) for meter size selection. The meter will remain accurate at flow rates higher than its rating, but over-ranging a meter for long periods can cause excessive bearing wear and pressure drop and shorten the life span of the meter. NUFLO flow meters can be over-ranged by 10% for short periods without damage.

Installation

- The meter should be installed so that the arrow on the meter body corresponds to the flow direction of the line.
- A 10 diameter length of straight unrestricted pipe must be upstream and a five diameter length of straight unrestricted pipe must be downstream of the flow meter. Both pipe sections should be the same nominal pipe size as the flow meter's end connection.
- Throttling/control valves should be located downstream of the flow meter.

Magnetic Pickup/Electronics Installation

- The meter's permanent conduit connection has 1" MNPT threads for attaching an electronic readout instrument.
- The conduit connection is designed for use with a 5/8" to 18" threaded magnetic pickup which is sold separately by Cameron.

Linear Flow Range ^(1, 2, 3)

Flow Meter Size ⁽³⁾					Nominal ⁽²⁾ Calibration Factor		Maximum Output Frequency	ΔP at Maximum Flow ⁽²⁾	
in.	mm	GPM	m ³ /HR	BPD	Pulses Gallon	Pulses x 1000/m ³	Pulses/Sec	psi	kPa
3/8	10	0.3 – 3	0.068 – 0.68	10 – 100	22000	(5812)	1100	4.0	28
3/8	10	0.3 – 3	0.068 – 0.68	10 – 100	22000	(5812)	1100	4.0	28
1/2	13	0.75 – 7.5	0.17 – 1.70	25 – 250	14500	(3830)	1815	12.0	83
3/4	19	2 – 15	0.45 – 3.41	68 – 515	2950	(780)	740	18.0	124
7/8	22	3 – 30	0.68 – 6.81	100 – 1000	2350	(621)	1175	20.0	138
1	25	5 – 50	1.14 – 11.36	170 – 1700	900	(238)	750	20.0	138
1-1/2	38	15 – 180	3.41 – 40.88	515 – 6000	325	(86)	975	16.0	110
2	51	40 – 400	9.09 – 90.85	1300 – 13,000	55	(14.5)	365	22.0	152
3	76	80 – 800	18.16 – 181.66	2750 – 27,500	57	(15.2)	760	20.0	138
4	102	100 – 1200	22.71 – 272.55	3400 – 41,000	30	(7.9)	600	10.0	69
6	152	250 – 2500	56.78 – 567.82	8600 – 86,000	7	(1.8)	290	10.0	6
8	203	350 – 3500	79.49 – 794.94	12,000 – 120,000	3	(.8)	175	6.0	41

⁽¹⁾ The linear flow range of liquids with non-lubricating characteristics is limited to the upper 60% of rating.

⁽²⁾ Based on water.

⁽³⁾ Consult Cameron's Measurement Systems division for engineering assistance with applications involving liquids of viscosities greater than 5 centistokes on 3/8" through 3/4" meters.

End Connections

NUFLO flow meters are available in a variety of end connections:

- Threaded
- Grooved
- Flanged
- EZ-IN
- WECO 1502

Threaded (NPT) End Connections

- Threaded meter sizes range from 3/8" to 2".
- Meter sizes from 3/8" to 1" pipe all have 1" NPT end connections to simplify meter size changes.
- All meter sizes other than the 2" have male threads.

Flow Meter Size x End Connection Size	Working Pressure		Length	
	psi	MPa	in.	mm
3/8 x 1	7500	51.7	4.0	102
1/2 x 1	7500	51.7	4.0	102
3/4 x 1	7500	51.7	4.0	102
7/8 x 1	5000	34.5	4.0	102
1 x 1	5000	34.5	4.0	102
1-1/2 x 1-1/2	5000	34.5	6.0	152
1-1/2 x 2	5000	34.5	6.0	152
2 x 2	5000	34.5	10.0	254
3 x 3	1000	6.9	12.5	318
4 x 4	1000	6.9	12.0	305

Flanged End Connections

Turbine flow meters with flanged end connections are available in both raised-face (RF) models and ring-type joint (RTJ) models. Flanged NUFLO meters are constructed with carbon steel or stainless steel slip-on flanges or machined from a single block of stainless steel. Slip-on flanges are welded to the outside of the meter to ensure that the flange never comes into contact with the process fluid. The flanges are designed to mate with ANSI B16.5 flanges. Contact the factory for availability of materials and construction types for a desired meter size.

Flow Meter Size x End Connection Size	Flange Pressure Rating	Length	
		in.	mm
3/8 x 1/2	150, 300, 600	5.0	127.0
	900, 1500, 2500	6.25	158.8
1/2 x 1/2	150, 300, 600	5.0	127.0
	900, 1500, 2500	6.25	158.8
3/4 x 3/4	150, 300, 600	5.0	127.0
	900, 1500, 2500	6.25	158.8
7/8 x 1	150, 300, 600, 900, 1500, 2500	6.0	152.4
1 x 1	150, 300, 600, 900, 1500, 2500	6.0	152.4
1-1/2 x 1-1/2	150, 300, 600, 900, 1500, 2500	7.0	177.8
2 x 2	150, 300, 600, 900, 1500, 2500	8.5	215.9
3 x 3	150, 300, 600, 900	10.0	254.0
	1500	12.0	304.8
	2500	15.0	381.0
4 x 4	150, 300, 600, 900	12.0	304.8
	1500	14.0	355.6
	2500	16.5	419.1
6 x 6	150, 300, 600, 900	12.0	304.8
	1500	16.0	406.4
8 x 8 ⁽¹⁾	150, 300, 600, 900	12.0	304.8

⁽¹⁾Contact factory for other flange classifications above 900#.

Flange Pressure Rating	Design-operating Temperature Range		Maximum Working Pressure Flange Material			
			Carbon Steel		Stainless Steel	
psi						
150	-20° F to 100° F	(-29° C to 38° C)	285 psi	1.96 mPa	275 psi	1.89 mPa
	-20° F to 200° F	(-29° C to 93° C)	260 psi	1.79 mPa	235 psi	1.62 mPa
	-20° F to 400° F	(-29° C to 204° C)	200 psi	1.38 mPa	195 psi	1.34 mPa
	-20° F to 450° F	(-29° C to 232° C)	185 psi	1.28 mPa	183 psi	1.26 mPa
300	-20° F to 100° F	(-29° C to 38° C)	740 psi	5.10 mPa	720 psi	4.96 mPa
	-20° F to 200° F	(-29° C to 93° C)	680 psi	4.69 mPa	600 psi	4.14 mPa
	-20° F to 400° F	(-29° C to 204° C)	635 psi	4.38 mPa	495 psi	3.41 mPa
	-20° F to 450° F	(-29° C to 232° C)	620 psi	4.27 mPa	480 psi	3.31 mPa
600	-20° F to 100° F	(-29° C to 38° C)	1480 psi	10.2 mPa	1440 psi	9.92 mPa
	-20° F to 200° F	(-29° C to 93° C)	1360 psi	9.38 mPa	1200 psi	8.27 mPa
	-20° F to 400° F	(-29° C to 204° C)	1265 psi	8.72 mPa	995 psi	6.86 mPa
	-20° F to 450° F	(-29° C to 232° C)	1235 psi	8.52 mPa	963 psi	6.64 mPa
900	-20° F to 100° F	(-29° C to 38° C)	2220 psi	15.3 mPa	2160 psi	14.9 mPa
	-20° F to 200° F	(-29° C to 93° C)	2035 psi	14.0 mPa	1800 psi	12.4 mPa
	-20° F to 400° F	(-29° C to 204° C)	1900 psi	13.1 mPa	1490 psi	10.3 mPa
	-20° F to 450° F	(-29° C to 232° C)	1855 psi	12.6 mPa	1443 psi	9.95 mPa
1500	-20° F to 100° F	(-29° C to 38° C)	3705 psi	25.5 mPa	3600 psi	24.8 mPa
	-20° F to 200° F	(-29° C to 93° C)	3395 psi	23.4 mPa	3000 psi	20.7 mPa
	-20° F to 400° F	(-29° C to 204° C)	3170 psi	21.8 mPa	2485 psi	17.1 mPa
	-20° F to 450° F	(-29° C to 232° C)	3093 psi	21.3 mPa	2408 psi	16.6 mPa
2500	-20° F to 100° F	(-29° C to 38° C)	6170 psi	42.5 mPa	6000 psi	41.3 mPa
	-20° F to 200° F	(-29° C to 93° C)	5655 psi	39.0 mPa	5000 psi	34.5 mPa
	-20° F to 400° F	(-29° C to 204° C)	5280 psi	36.4 mPa	4140 psi	28.5 mPa
	-20° F to 450° F	(-29° C to 232° C)	5153 psi	35.5 mPa	4010 psi	27.6 mPa

Test Pressure: 1.5 times maximum working pressure at -20° F to 100° F (-29° C to 38° C)

Grooved End Connection

Flow meters with grooved end connections are available in 7/8" through 8" sizes.

Flow Meter Size x End Connection Size	Length		Working Pressure	
	in.	mm	psi	MPa
7/8 x 1	4.0	102	1000	6.9
1 x 1	4.0	102	1000	6.9
1-1/2 x 1-1/2	6.0	152	1000	6.9
1-1/2 x 2	6.0	152	1000	6.9
1-1/2 x 2	6.0	152	2500	17.2
2 x 2-1/2	10.0	254	1000	6.9
3 x 3	12.5	318	1000	6.9
4 x 4	12.0	305	1000	6.9
6 x 6	12.0	305	800	5.5
8 x 8	12.0	305	800	5.5

WECO 1502 Union End Connection

Flow meters with WECO 1502 end connections are commonly used in high-pressure oilwell service applications. Meter sizes 1", 1-1/2" and 2" have 2" union end connections with a wing nut on one end and threads on the other end. The 3" meters have 3" union end connections with the option of a wing nut on one end and threads on the other, or threads on both ends. All WECO 1502 union end connection meters have two pickup adapters.

Flow Meter Size x End Connection Size	Length		Working Pressure	
	in.	mm	psi	MPa
1 x 2	8.00	203.3	15,000	103
1-1/2 x 2	8.60	218.4	15,000	103
2 x 2	9.00	228.6	15,000	103
3 x 3	13.0	330.2	15,000	103

EZ-IN End Connection

EZ-IN series turbine flow meters provide a cost-effective alternative to typical flanged meters. They offer the accuracy, rugged construction, and maintenance-free operation of conventional NUFLO flow meters plus the following advantages:

- Lower installation cost
- Less expensive than a conventional, flanged meter
- Easy installation, removal and inspection
- Mates to any raised-face flange rated ANSI 150# to 1500#
- Mates to any ring joint flange rated ANSI 900#, 1500# or 2500#
- Reduced-bore designs (e.g. 1" x 2" end connection) enable flow range adjustments without changing end connections.

Specialized Flow Meters

- High pressure
- Nitrogen
- CO₂
- Cement slurry
- Corrosive service
- Drilling fluids

Meters for use with Raised Face Flanges^(1, 3)

Flow Meter Size x End Connection Size ⁽²⁾	Lengths, in. (mm)					
	1	2	3	4	6	8
3/8 x 1	4.0 (102)	—	—	—	—	—
1/2 x 1	4.0 (102)	—	—	—	—	—
3/4 x 1	4.0 (102)	—	—	—	—	—
7/8 x 1	4.0 (102)	—	—	—	—	—
1 x 1	4.0 (102)	—	—	—	—	—
3/8 x 2	—	2.5 (63.5)	—	—	—	—
1/2 x 2	—	2.5 (63.5)	—	—	—	—
3/4 x 2	—	2.5 (63.5)	—	—	—	—
7/8 x 2	—	2.5 (63.5)	—	—	—	—
1 x 2	—	2.5 (63.5)	—	—	—	—
1-1/2 x 2	—	2.5 (63.5)	—	—	—	—
2 x 2	—	2.5 (63.5)	—	—	—	—
2 x 3	—	—	4.25 (108)	—	—	—
3 x 3	—	—	4.25 (108)	—	—	—
4 x 4	—	—	—	5.0 (127)	—	—
6 x 6	—	—	—	—	5.75 (146.1)	—
8 x 8 ⁽³⁾	—	—	—	—	—	6.25 (158.8)

⁽¹⁾ Specify flange type (raised face or ring joint) when ordering.

⁽²⁾ Cameron offers multiple flow meter sizes for many end connection sizes, making it easy to adapt to changing flow rates

⁽³⁾ CE-marked meter requires special centering rings.

Contact Cameron's Measurement Systems division for application assistance.

Meters for use with Ring Joint Flanges¹

Flow Meter Size x End Connection Size	Lengths, in. (mm)					
	1	2	3	4	6	8
1 x 2	—	3.5 (88.9)	—	—	—	—
1-1/2 x 2	—	3.5 (88.9)	—	—	—	—
2 x 2	—	3.5 (88.9)	—	—	—	—
3 x 3	—	—	4.25 (108)	—	—	—
4 x 4	—	—	—	5.0 (127)	—	—
6 x 6	—	—	—	—	5.75 (146.1)	—
8 x 8	—	—	—	—	—	6.25 (158.8)

¹ Specify flange type (raised face or ring joint) when ordering.

Pressure Drop Curve for NUFLO Turbine Flow Meters

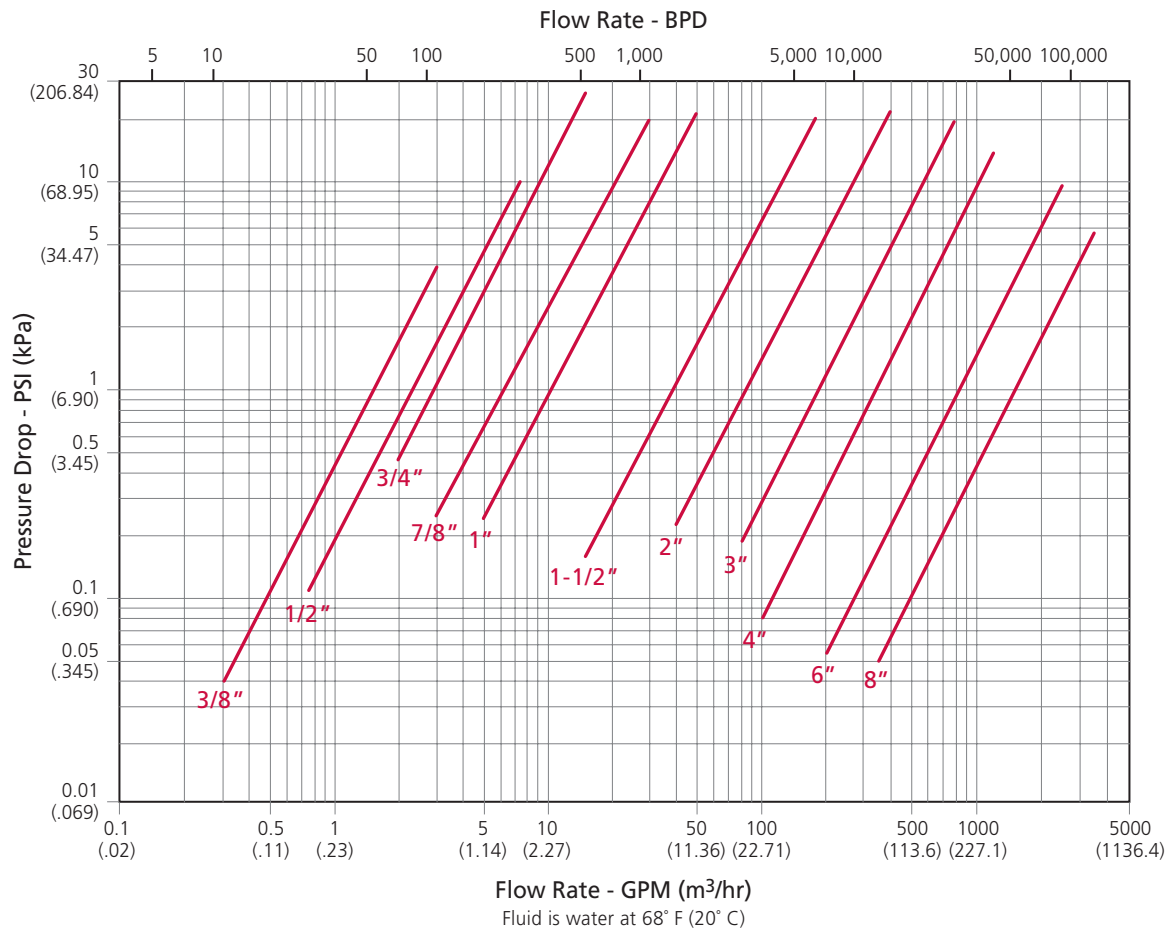



NORTH AND SOUTH AMERICA

14450 JFK Blvd.
Houston, TX 77032
USA
Tel 1 281 582 9500
ms-us@c-a-m.com

EUROPE, AFRICA, CASPIAN AND RUSSIA

3 Steyning Way
Southern Cross Trading Estate
Bognor Regis
West Sussex PO22 9TT
England, UK
Tel 44 1243 826741
ms-uk@c-a-m.com

ASIA PACIFIC

Suite 16.02 Menara AmFirst
No. 1 Jalan 19/3
46300 Petaling Jaya
Selangor Darul Ehsan
Malaysia
Tel 603 7954 0145
ms-kl@c-a-m.com

MIDDLE EAST

Level 9, Al Jazira Club Tower A
P.O. Box 47280, Muroor Road
Abu Dhabi
United Arab Emirates
Tel 971 2 596 8400
ms-uk@c-a-m.com